

[ E[M]CONOMY ]  
means:

**emco**group

Designed for your profit

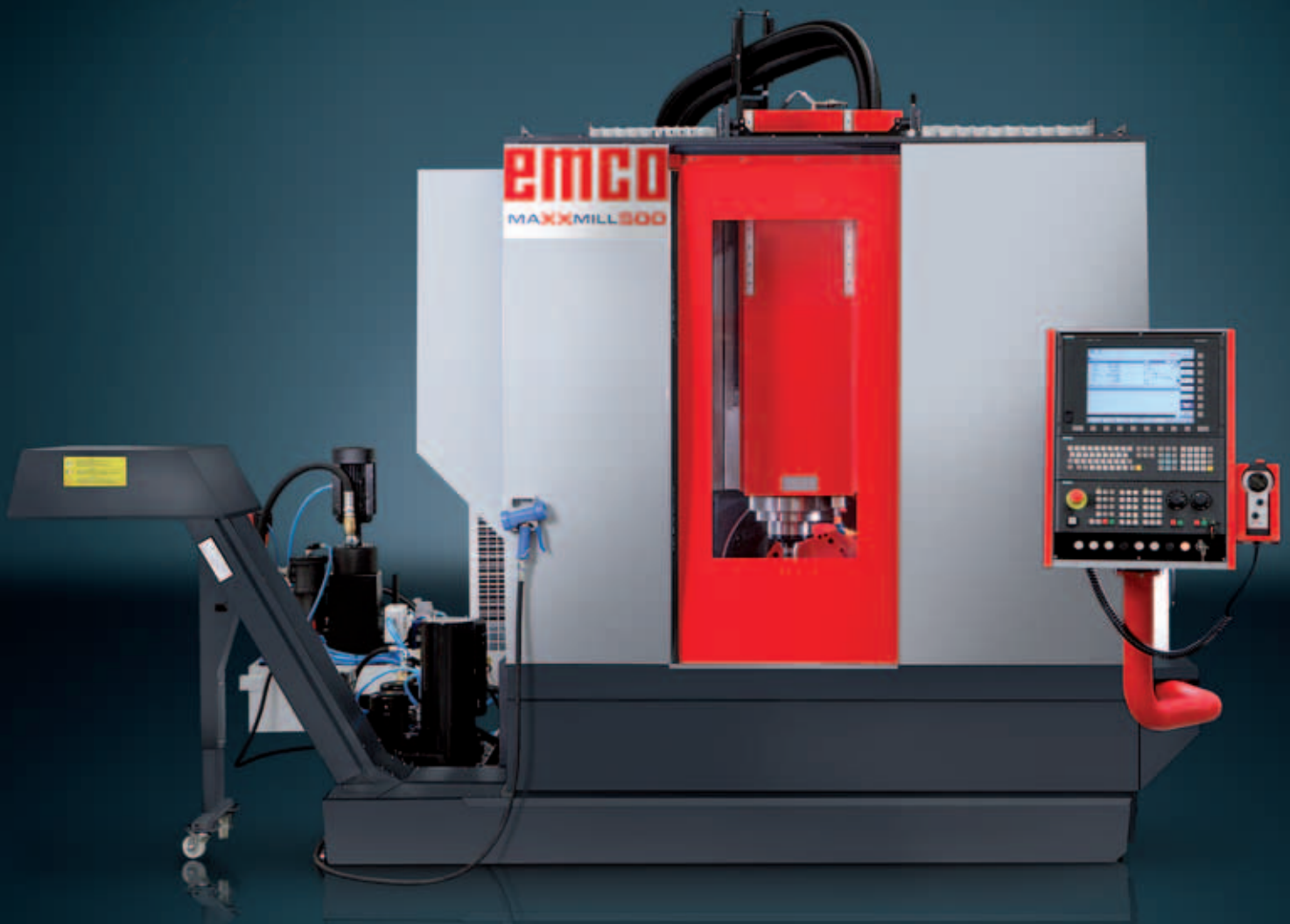

**Save time, money and space!**  
**MAXXMILL 500**

**Vertical milling center for 5-side machining**

# MAXXMILL 500

MAXXMILL 500 is the ideal vertical milling center for the 5-sided machining of parts in low or medium quantities. It is the perfect machine for jobshops, industrial businesses (e.g. automobile vendors), general mechanical engineering companies and further education facilities. The new MAXXMILL 500 can mill parts with an edge size of 500 x 500 x 475 mm on 5 sides in just one operation.

## [Spindle]

- Mechanical spindle direct drive: 10000 rpm
- Motor spindle: 15000 rpm

## [Tool changer]

- Tool changer with 30 tool stations

## [Operating panel]

- Available with Heidenhain or Siemens control technology
- Swivelling and rotatable operating panel

## [Machine base]

- The machine base is made of hydropol the X-axis slide is made of welded steel.

## [Chip removal]

- The chip removal can be handled by an optional available hinge type chip conveyor. A chip flushing system is standard in the base machine.

## [Table]

- Tilting-rotary table

# [Workpieces]



Housing  
(Cast steel)



Distributor  
(Brass)



Pump housing  
(Aluminium)

# [Machine construction]

The new MAXXMILL 500 series is designed as a column milling machine. The machine bed is made of good vibration-damping hydropol. The X-axis slide is a welded steel design, the Y- and Z-axis slide are made of tension free cast.

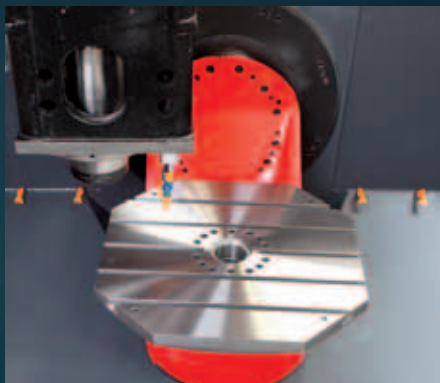
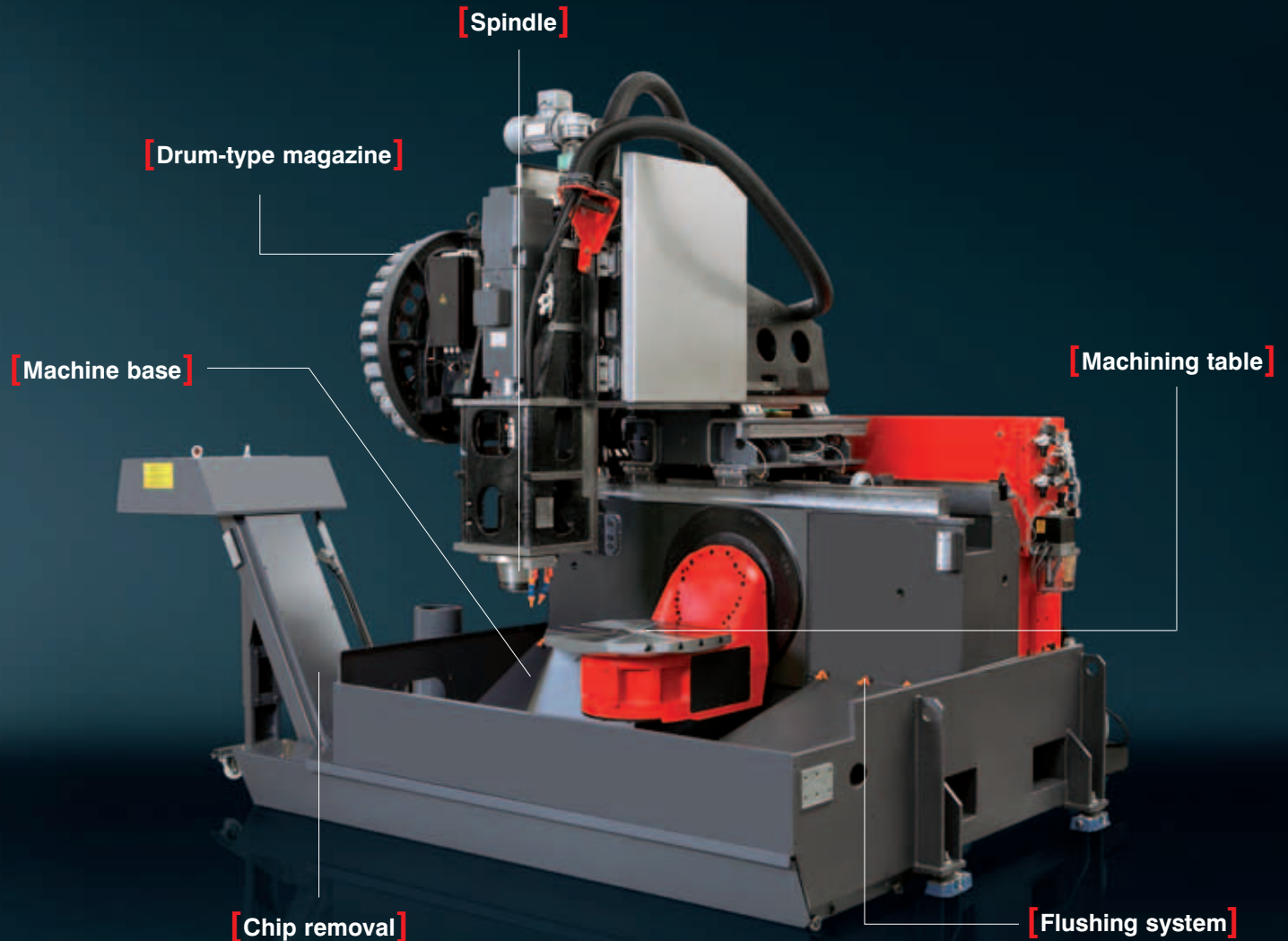

The tilting-rotary table has a large clamping area of 600 x 600 mm and can bear loads of up to 250 kg. This makes it possible to simply machine workpieces with an edge size of 500 x 500 x 475 mm.



With a travel range of  $\pm 100^\circ$ , the B axis provides a larger work area than most products from other manufacturers. The C axis can be infinitely rotated by  $360^\circ$ .



The tool changer has 30 tool stations. The tools are managed according to the variable tool station coding principle (random), which means that tools are always deposited in the first free magazine station for time reasons.

# [Engineering]

## Highlights

- 5-side machining in just one operation
- Top thermostability
- Top cutting precision
- Mechanical or motor spindle
- Compact machine design
- Cutting-edge control technology from Siemens and Heidenhain
- Very attractive price
- Made in the Heart of Europe

## Power

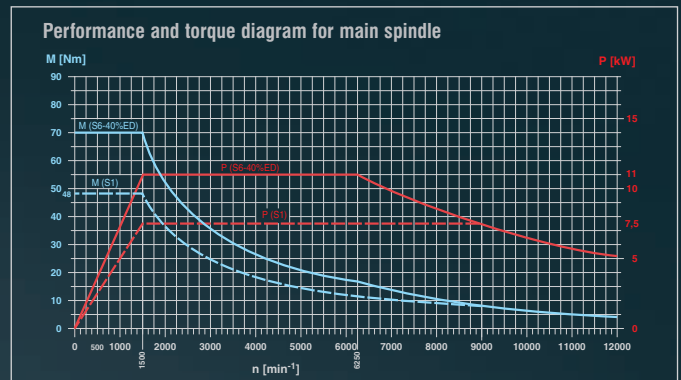

Tool changes are carried out mechanically by a dual-gripper arm in just 1.6 seconds, making the system extremely reliable.



The MAXXMILL 500 uses state-of-the-art control technology. The Heidenhain TNC620 and the Siemens 840D Solution Line are the newest products on the market and provide optimum CNC control experiences for both operators and programmers.



The chips can be discarded manually at the side of the machine or with the optional available hinge type chip conveyor to the left side of the machine. With a discard height of 1100 mm the chips can be dropped easily into a chip tray or similar containers.

# [Options]

- Coolant pistol
- Alarm status lamp
- Electric cabinet air-conditioning unit
- Automatic workpiece set-up
- Tool monitoring with laser
- Coolant through the spindle, 20 bar
- Air/water through the spindle
- 4-way rotary coupling on table center
- Integrated hydraulic unit
- Belt filter
- Rotating inspection glass on door
- Workspace cover
- Automatic machine door
- Linear scales in all 3 axes X-Y-Z

# Assembly plan and work area layout

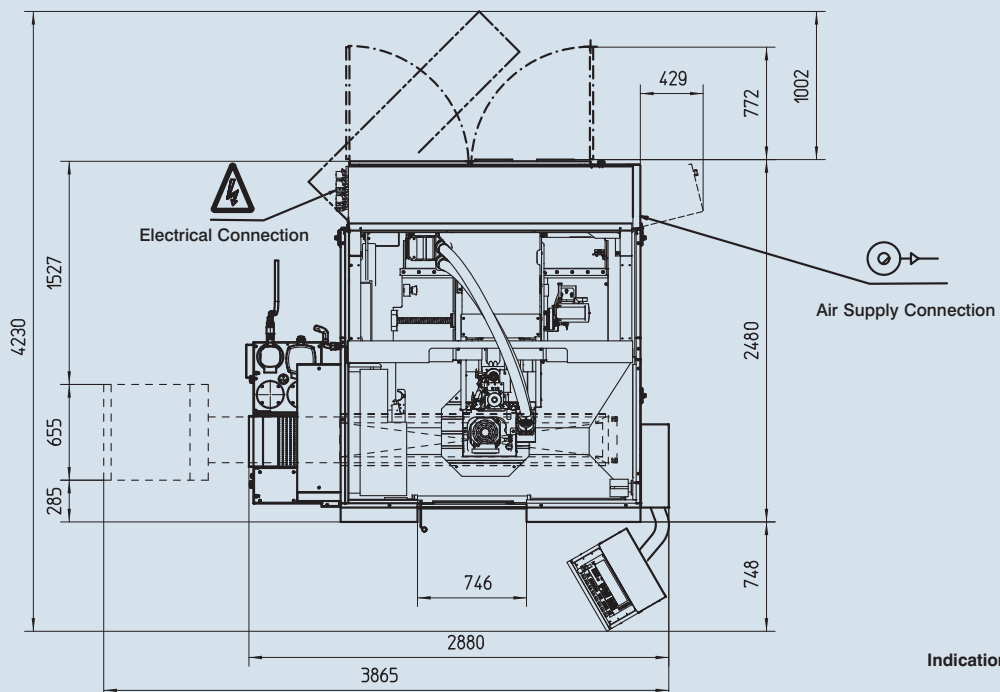
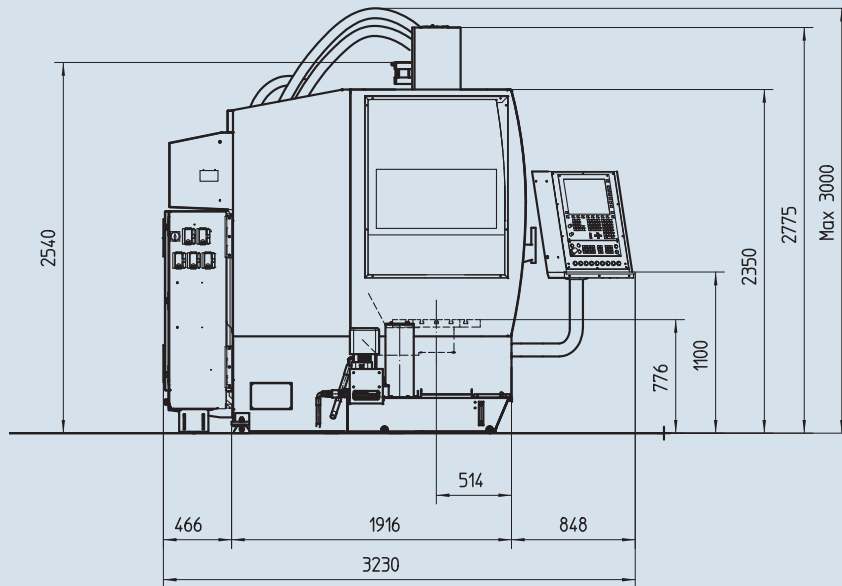
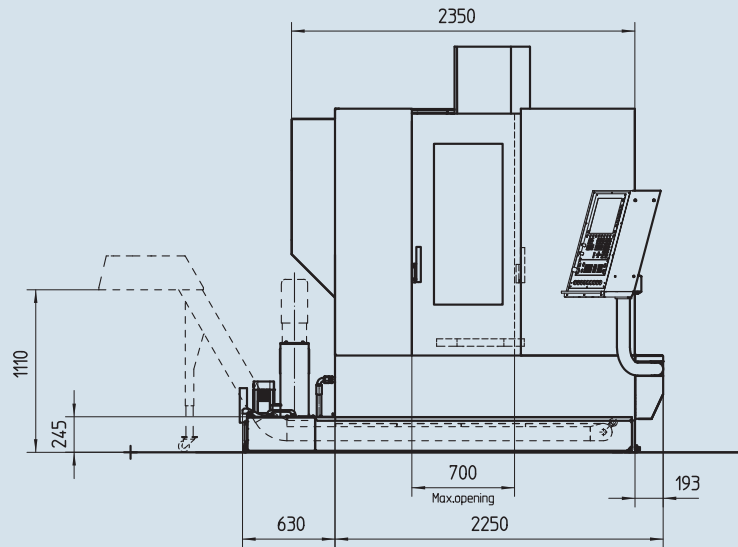

Indications in millimeters

# [Technical data]

**emco** group

Designed for your profit

## MAXXMILL 500

Travel and tolerances	
Travel in X (without 100 mm extra-stroke for tool change)	650 mm (25.6")
Travel in Y	550 mm (21.7")
Travel in Z	500 mm (19.7")
Distance spindle nose - table (min – max)	150/650 mm (5.9"/16.9")
Movement B axis (tilting)	+/-100°
Movement B axis (table)	0 – 360°
Positioning accuracy P according to VDI 3441 *	16 µm
Positioning repeatability P according to VDI 3441 *	3 µm
Positioning accuracy B axis (tilting – with motor encoder)	10 sec.
Positioning accuracy C axis (table – with motor encoder)	20 sec.
Feed	
Rapid motion speed X-Y-Z axis	30 m/min (1181.1 ipm)
Max. rotational speed B axis	25 rpm
Max. rotational speed C axis	25 rpm
Max. feed force X axis	5000 N (1124 lbs)
Max. feed force Y axis	5000 N (1124 lbs)
Max. feed force Z axis	5000 N (1124 lbs)
Max. acceleration X-Y-Z axis	3 m/s <sup>2</sup>
Tilting table	
Clamping area	600 x 600 mm (23.6 x 23.6")
Table-floor distance	776 mm (30.6")
Slot number	5
Slot wheel base	100 mm (3.9")
Max. workpiece weight (equally distributed)	250 kg (551.2 lb)
Main spindle (mechanical spindle)	
Speed range	50 – 10000 rpm
Maximum spindle torque	70 Nm (51.6 ft/lbs)
Maximum spindle power	11 kW (14.8 hp)
Tool taper	ISO 40 DIN 69871
Pull stud	ISO 7388/2 type B
Drive	Direct with coupling

\* Values measured at a temperature of 22°C, with the machine mounted on the floor. Standard machine, without linear scales or external encoders on the table.

Main spindle (motor spindle)	
Speed range	50 - 15000 rpm
Maximum spindle torque	110 Nm (81.1 ft/lbs)
Maximum spindle power	34,5 kW (46,3 hp)
Tool magazine	
Number of tool stations	30
Tool changing type	With changing arm
Tool management	Random
Tool changing time (tool-tool)	1.6 sec
Max. tool diameter	80 mm (3.1")
Max. tool diameter (without neighbouring tools)	125 mm (4.9")
Max. tool length	250 mm *9.8")
Max. tool weight	8 kg (17.6 lb)
Total tool weight supported by the magazine	100 kg (220.5 lb)
Coolant tank	
Tank capacity	250 l (66.0 gal)
Standard pump pressure	2 bar (29.0 PSI)
Max. capacity at 2 bar	40 l/min (10.6 gal/min)
Pneumatic supply	
Min. pressure supply	5.5 bar (79.8 PSI)
Min. capacity required	200 NI/min
Lubrication	
Spindle	Grease
Caged ball ways	Oil / central lubrication
Ball screws	Oil / central lubrication
Dimensions	
Total height	3000 mm (118.1")
Dimensions L x D	2430 x 3500 mm (95.7 x 137.8")
Weight	9200 kg (20,283 lb)



EN7175 - 02/11 - Technical modifications reserved. Errors and omissions excepted.

[www.emco-world.com](http://www.emco-world.com)